

Double Groove Belt Drive Conveyor Drum Roller For Conveying Cartons Packages And Small Components

Our Product Introduction

Basic Information

- Place of Origin: China Jiangsu
- Brand Name: Winroller
- Certification: CE,SGS,ISO9001,ROHS,UL
- Model Number: Winroller Double Groove Belt Driven Conveyor Drum Roller
- Minimum Order Quantity: 1stick
- Price: Contact Us
- Packaging Details: Wooden case
- Delivery Time: 7-15 word days
- Payment Terms: TT, L/C
- Supply Ability: 1000000/year



Product Specification

- Product Name: Double Groove Belt Drive Conveyor Drum Roller
- Drive Mode: Double Groove Belt Driven
- Application: Suitable For Conveying Cartons Packages And Small Components
- WidthPipe Diameter: $\Phi 50\text{mm}$ $\Phi 60\text{mm}$
- Material: Durable Steel Or Polymer
- Customizable: Adjustable Groove Positions
- Protection: End Caps Guard Against Dust And Water
- Temperature Range: -5 To +40
- Noise Level: Quiet Operation
- Bearings: Precision Ball Bearings For Smooth Operation
- Highlight: **Double Groove Belt Drive Roller, Conveying Cartons Belt Drive Roller, Double Groove belt conveyor roller**



for more products please visit us on drum-roller.com

Product Description

Double Groove Belt Drive Conveyor Drum Roller For Conveying Cartons Packages and Small Components

Features Overview of Double Groove Belt Drive Conveyor Drum Roller

Based on the design of A20 series
Simple structure, groove position can be customized
Standard anti-static design
Anti-rust, beautiful; Quiet
The "O" belt circumference is not limited, and the drum spacing is free

Remark:

Roll groove position: minimum to side: 35mm, minimum distance between two grooves: 30mm
The driving force and transmission efficiency are low, and the later maintenance is maximum

Application of Double Groove Belt Drive Conveyor Drum Roller

Material Handling: Efficient for conveying light to medium-duty materials such as cartons, packages, and small components.

Technical Parameters of Double Groove Belt Drive Conveyor Drum Roller

Double Groove Belt Drive Conveyor Drum Roller

| Pipe diameter and wall thickness | Bearing | Axis center | Roller material | |
|----------------------------------|---------|--------------|-------------------------|-----------|
| | | | Galvanized carbon steel | Stainless |
| φ50*1.5 | 6002 | 11hex,φ12/15 | √ | √ |
| φ60*2.0 | 6002 | 11hex,φ12/15 | √ | √ |

Profile and parameter introduction

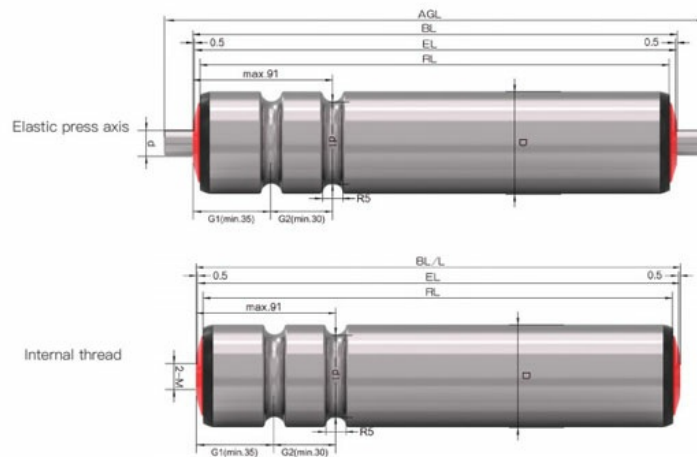

- ★ Design based on A20 series
- ★ Simple structure, groove position can be customized
- ★ Standard anti-static design
- ★ Anticorrosive rust, beautiful; Quiet operation
- ★ "O" belt circumference is not limited, drum spacing is free

Remark:

Position of the drum groove: minimum at the end: 35mm
The driving force and convey efficiency are low, and the maintenance is maximum later

RL: roll length

EL: effective length

AG L: axis general length

Important installation size: base frame inner width (BF)

Feature Picture of Double Groove Belt Drive Conveyor Drum Roller





WIN ROLLER JIANG SU Winroller Technology Co., Ltd.

+86 18168399322

winroller.market@gmail.com

drum-roller.com

No. 7, Xiye Road, Huishan District, Wuxi City, Jiangsu Province, China